

Honeywell

Model 41

Precision Low Profile Load Cell



DESCRIPTION

Model 41 is a low profile "pancake" type load cells. These bonded foil, strain gage load cells are engineered to measure loads from 5 lb to 500,000 lb. The tension/ compression Model 41 is designed with the threaded hole running completely through the center of the cell. Model 41 utilizes two stabilizing diaphragms, which are welded to the sensing member to

reduce off-center and side-loading effects. It provides high performance in non-linearity, hysteresis, and repeatability specifications for such applications as tube mills, extruding processes and weighing. Each unit has a welded construction and can be hermetically sealed for added durability. Model 41 load cells are available with optional 0 Vdc to 5 Vdc or 4 mA to 20 mA output.



FEATURES

- 0.1 % accuracy
- 5 lb to 500000 lb
- mV/V output (standard); 4 mA to 20 mA and 0 Vdc to 5 Vdc (optional) outputs
- Double diaphragm design
- Intrinsically safe available (2N option only)¹⁶
- CE approved¹⁷

Courtenay House, Monument Way East, Woking,
Surrey GU21 5LY, United Kingdom

Tel: +44(0)844 443 7925
Fax: +44(0)844 443 7928

Web Site: www.medcotas.com

Model 41

PERFORMANCE SPECIFICATIONS

Characteristic	Measure
Load ranges ¹	5 lb to 500000 lb
Non-linearity, 5 lb to 25 lb	±0.2 % full scale
Hysteresis, 50 lb to 500000 lb	±0.1 % full scale
Hysteresis, 5 lb to 25 lb	±0.1 % full scale
Hysteresis, 50 lb to 500000 lb	±0.09 % full scale
Non-repeatability, 5 to 25 lb	±0.1 % full scale
Non-repeatability, 50 lb to 500000 lb	±0.03 % full scale
Output (tolerance), 5 lb to 25 lb	2 mV/V ±0.5 % full scale
Output (tolerance), 50 lb to 500000 lb	3 mV/V ±0.5 % full scale
Operation	Compression/tension ¹
Resolution	Infinite
Standard calibration	5-point calibration: 0 %, 50 % and 100 % of full scale in tension only

ENVIRONMENTAL SPECIFICATIONS

Characteristic	Measure
Temperature, operating	-54 °C to 121 °C [-65 °F to 250 °F]
Temperature, compensated	15 °C to 71 °C [60 °F to 160 °F]
Temperature effect, zero	0.002 % full scale/°F
Temperature effect, span	0.002 % full scale/°F

ELECTRICAL SPECIFICATIONS

Characteristic	Measure
Strain gage type	Bonded foil
Excitation (calibration)	10 Vdc
Insulation resistance	5000 mOhm @ 50 Vdc
Bridge resistance (tolerance)	350 ohm (nominal)
Zero balance (tolerance)	±1 % full scale
Shunt calibration data	Included
Electrical termination (std) 5 lb to 5000 lb	PTIH-10-6P
Electrical termination (std) 7500 lb to 500000 lb	MS3102E-14S-6P
Mating connector 5 lb to 5000 lb (not incl.)	PT06A-10-6S or equiv. (AA111)
Mating connector 7500 to 500000 lb (not incl.)	MS3106A-14S-6S (AA121)

2 Honeywell • Sensing and Control

MECHANICAL SPECIFICATIONS

Characteristic	Measure
Maximum allowable load	150 % FS ¹
Weight	See table
Material Less than 200,000 lb	17-4PH stainless steel
Material greater than or equal to 300000 lb	Carbon steel
Deflection	See table
Natural frequency	See table

RANGE CODES

Range Code	Available ranges	Range Code	Available ranges
AT	5 lb	DV	10000 lb
AV	10 lb	EJ	15000 lb
BL	25 lb	EL	20000 lb
BN	50 lb	EN	30000 lb
BR	100 lb	EP	50000 lb
CN	250 lb	ER	75000 lb
CR	500 lb	ET	100000 lb
CV	1000 lb	FJ	150000 lb
DL	2000 lb	FL	200000 lb
DN	3000 lb	FN	300000 lb
DP	4000 lb	FP	400000 lb
DR	5000 lb	FR	500000 lb
DT	7500 lb		

WIRING CODES

Connector	Unamplified (Std.)
A	(+) excitation
B	(+) excitation
C	(-) excitation
D	(-) excitation
E	(-) output
F	(+) output

DEFLECTIONS AND RINGING FREQUENCIES

Capacity (lb)	Deflection @ full scale (in)	Natural ringing frequency (Hz)	Weight (lb)
5 to 25	0.001	2000	0.8
50 to 1000	0.002	4600	1.5
2000 to 5000	0.002	10000	2.0
7500 to 15000	0.003	6000	8.8
20000 to 50000	0.004	8000	11.0
75000 to 100000	0.006	5500	30.9
150000 to 200000	0.010	4500	46.3
300000 to 500000	0.010	4100	130.1

Precision Low Profile Load Cell

INTERNAL AMPLIFIERS

Amplifier specifications	Voltage output: Option 2b	Voltage output: Option 2c	Voltage output: Option 2t	Current three-wire: Option 2j	Current two-wire: Option 2k	Intrinsically safe amp: Option 2n (2N)***
Output signal	±5 V	0-5 V or ±5 V @ 45 mA	0-10 V or ±10 V @ 45 mA	4 mA to 20 mA	4 mA to 20 mA	4 mA to 20 mA
Input power (voltage)	±15 Vdc or 26-32 Vdc	11 Vdc to 28 Vdc	15 Vdc to 28 Vdc	22 Vdc to 32 Vdc	15 Vdc to 40 Vdc	9 Vdc to 28 Vdc
Input power (current)	45 mA	40 mA	40 mA	65 mA	4 mA to 28 mA	4 mA to 24 mA
Freq. response	3000 Hz	3000 Hz	3000 Hz	2500 Hz	300 Hz	2000 Hz
Power supply rejection	60 db	60 db	60 db	60 db	60 db	60 db
Operating temperature	-20 °F to 185 °F	-20 °F to 185 °F	-20 °F to 185 °F	0 °F to 185 °F	0 °F to 185 °F	-20 °F to 185 °F
Reverse volt. protection	Yes	Yes	Yes	Yes	Yes	Yes
Short circuit protection	Momentary	Momentary	Momentary	Yes	Yes	Yes
Wiring code: connector	A (+) Supply B Output common C Supply return D (+) Output E Shunt Cal 1 F Shunt Cal 2	A (+) Supply B Output common** C Supply return** D (+) Output E Shunt Cal 1 F Shunt Cal 2	A (+) Supply B Output common** C Supply return** D (+) Output E Shunt Cal 1 F Shunt Cal 2	A (+) Supply B Output common** C Supply return** D (+) Output E Shunt Cal 1 F Shunt Cal 2	A (+) Supply B No connection C No connection D (+) Output E Case ground F No connection	A (+) Supply B No connection C No connection D (+) Output E Case ground F No connection
Wiring code: cable	R (+) Supply Bl Output common G Supply return W (+) Output B Shunt Cal 1 Br Shunt Cal 2	R (+) Supply Bl Output com* G Supply return* W (+) Output B Shunt Cal 1 Br Shunt Cal 2	R (+) Supply Bl Output com* G Supply return* W (+) Output B Shunt Cal 1 Br Shunt Cal 2	R (+) Supply Bl Output com* G Supply return* W (+) Output B Shunt Cal 1 Br Shunt Cal 2	R (+) Supply Bl (+) Output W Case ground	R (+) Supply Bl (+) Output W Case ground

* Black and green wires are internally connected.

** Pins B and C are internally connected.

*** See our Web site for the most up-to-date information regarding intrinsically safe approvals, ref. #008-0547-00.

ALLOWABLE MAXIMUM LOADS

Capacity (lb)	Side load (lb)	Bending (lb-in)	Torque (lb-ft)
5 to 25	50 %	40 %	25 %
50 to 1000	45 %	35 %	25 %
2000 to 5000	30 %	25 %	25 %
7500 to 30000	20 %	20 %	15 %
50000 to 100000	20 %	20 %	15 %
150000 to 200000	20 %	20 %	15 %
300000	20 %	20 %	10 %
400000	20 %	20 %	10 %
500000	20 %	20 %	10 %

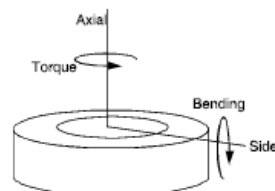

Model 41

OPTION CODES

	Many range/option combinations are available in our quick-ship and fast-track manufacture programs. Please see http://sensing.honeywell.com/TMsensor-ship for updated listings.			
Load ranges	5, 10, 25, 50, 100, 250, 500, 1000, 2000, 5000, 3000, 4000, 7500, 10000, 15000, 20000, 30000, 50000, 75000, 100000, 150000, 200000, 300000, 400000, 500000 lb			
Temperature compensation	1a. 60 °F to 160 °F 1b. 30 °F to 130 °F 1c. 0 °F to 185 °F	1d. -20 °F to 130 °F 1e. -20 °F to 200 °F 1f. 70 °F to 250 °F	1g. 70 °F to 325 °F ¹⁴ 1h. 70 °F to 400 °F ¹⁴ 1i. -65 °F to 250 °F ¹⁴	1j. 0 °C to 50 °C 1k. -20 °C to 85 °C 1m. -25 °C to 110 °C
Internal amplifiers ¹⁰	2b. 4 wire, ±5 Vdc 2c. 0-5 Vdc output	2j. 4-20 mA (three-wire) output 2k. 4 mA to 20 mA (two-wire) ²⁰	2n (2N) 4 mA to 20 mA (wire) intrinsically safe ²⁰ 2t. 0 Vdc to 10 Vdc	2u. Unamplified, mV/V output
Internal amplifier enhancements	3a. Input/output isolation ¹² 3d. Remote buffered shunt calibration ⁹			
Overload stops	4a. Overload stops			
Electrical termination	6a. Bendix PTIH-10-6P 6-pin (ranges to 5000 lb) 6b. MS3102E-14S-6P (ranges 7500 lb and up) ³ 6e. Integral cable: Teflon	6f. Integral cable: PVC 6g. Integral cable: Neoprene ⁹ 6h. Integral cable: Silicone	6i. Integral underwater cable ⁹ 6j. 1/2-14 conduit fitting with 5 ft of 4 conductor PVC cable	6q. Molded integral cable polyurethane ⁹ 6v. Phoenix connector on end of cable
Shunt calibration	8a. Precision internal resistor ¹⁴			
Special calibration	9a. 10 point (5 up/5 down) 20 % increments @ 68 °F 9b. 20 point (10 up/10 down) 10 % increments @ 68 °F 9c. ASTM E-74 calibration			
Bridge resistance	12b. 5000 ohm (foil)			
Zero and span adjustment	14a. No access to pots 14b. Top access to pots			
Electrical connector orientation	15a. Horizontal electrical exit port orientation 15b. Vertical electrical exit port orientation		15c. Radial electrical exit port orientation 15d. Connector on end of cable	
Special calibration	30a. Compression only calibration, positive in compression 30b. Tension and compression calibration, positive in tension 30c. Compression only calibration, negative in compression 30d. Tension and compression calibration, positive in compression			
Bridge type	31a. Dual bridge			
Shock and vibration	44a. Shock and vibration resistance			
Interfaces	53e. Signature calibration ¹⁴ 53t. TEDS IEEE 1451.4 module ¹⁵			

Precision Low Profile Load Cell

MOUNTING DIMENSIONS

Ranges lb	D mm [in]	H mm [in]	H*** mm [in]	F#	ØG mm [in] B.C.	ØK mm [in] thru	T	A mm [in]	A* mm [in]	B mm [in]	B* mm [in]	C mm [in]
5, 10, 25	63,5 [2.50]	20,32 [0.80]	44,45 [1.75]	6	50,8 [2.000]	4,83 [0.19]	1/4-28 UNF	20,83 [0.82]	63,5 [2.5]	19,05 [0.75]	22,86 [0.9]	31,75 [1.25]
50, 100, 250, 500, 1000	76,2 [3.00]	25,4 [1.00]	44,45 [1.75]	6	57,15 [2.250]	7,11 [0.28]	3/8-24 UNF	20,83 [0.82]	63,5 [2.5]	19,05 [0.75]	22,86 [0.9]	31,75 [1.25]
2000, 3000, 4000, 5000	88,9 [3.50]	25,4 [1.00]	44,45 [1.75]	6	66,68 [2.625]	8,64 [0.34]	1/2-20 UNF	20,83 [0.82]	63,5 [2.5]	19,05 [0.75]	22,86 [0.9]	31,75 [1.25]
7500, 10000, 15000	139,7 [5.50]	45,7 [1.80]	45,7 [1.80]	8	114,3 [4.500]	10,16 [0.40]	1-14 UNS	31,75 [1.25]	58,42 [2.3]	38,1 [1.50]	38,1 [1.5]	50,8 [2.00]
20000, 30000, 50000	152,4 [6.00]	45,7 [1.80]	45,7 [1.80]	8	123,83 [4.875]	13,46 [0.53]	1 1/2-12 UNF	31,75 [1.25]	58,42 [2.3]	38,1 [1.50]	38,1 [1.5]	50,8 [2.00]
75000, 100000	228,6 [9.00]	63,5 [2.50]	63,5 [2.50]	12	196,85 [7.750]	16,76 [0.66]	2-12 UN	31,75 [1.25]	58,42 [2.3]	38,1 [1.50]	38,1 [1.5]	50,8 [2.00]
150000, 200000	279,4 [11.00]	63,5 [2.50]	63,5 [2.50]	12	241,3 [9.500]	19,81 [0.78]	2 1/2-12 UN	31,75 [1.25]	58,42 [2.3]	38,1 [1.50]	38,1 [1.5]	50,8 [2.00]
300000, 400000, 500000	355,6 [14.00]	107,95 [4.25]	107,95 [4.25]	12	298,45 [11.750]	26,16 [1.03]	3 1/2-8 UN	31,75 [1.25]	58,42 [2.3]	38,1 [1.50]	38,1 [1.5]	**

* Length of load cell with amplified option (see option codes)

** C dimension varies on high ranges. Consult factory

*** H dimension with 2n(2N) amplifier

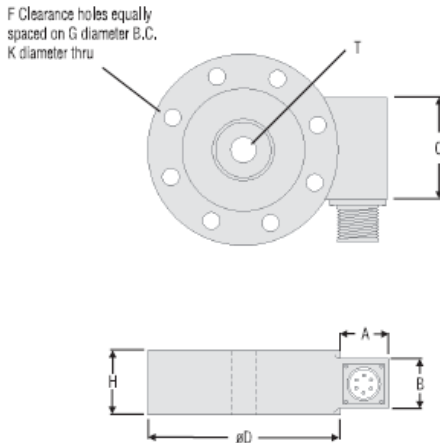

TYPICAL SYSTEM DIAGRAM

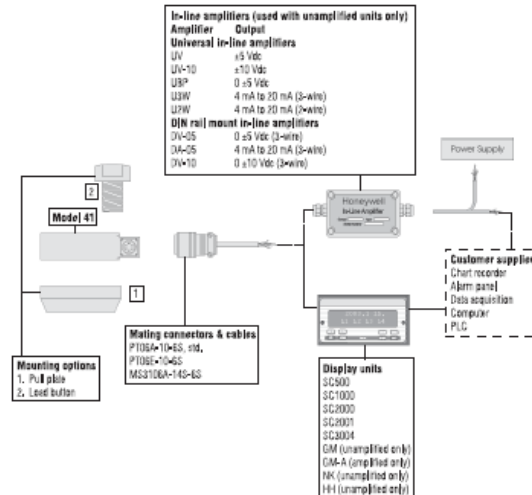

Model 41

Precision Low Profile Load Cell

NOTES

1. Allowable maximum loads - maximum load to be applied without damage.²
2. Without damage - loading to this level will not cause excessive zero shift or performance degradation. The user must consider fatigue life for long term use and structural integrity. All structurally critical applications (overhead loading, etc.) should always be designed with safety redundant load paths.
3. Interconnecting shunt cal. 1 terminal with shunt cal. 2 terminal provides 50 % (unamplified units), 75 % (4 mA to 20 mA 3-wire units) or 80 % (voltage amplified units) of full scale output for quick calibration. Shunt calibration comes standard with internal amplifier option 2b, 2c, 2t and 2j.
4. O=Orange; Y=Yellow; B=Blue; Bl=Black; R=Red; Br=Brown; W=White; G=Green. Color specifying cable and number or letter specifying connector.
5. No mating connector necessary for cable option.
6. Adding any internal amplifiers on 5 lb to 25 lb ranges will increase delivery time.
7. Option 2n (2N) on 5 to 5000 lb. ranges will typically take 12 weeks for delivery.
8. Option 3d is not available with option 2n (2N) or 2k.
9. Not available with option 1c, 1e, 1f, 1g, 1h or 1i.
10. Consult factory.
11. Availability varies with range, consult factory.
12. Option only pertinent when option 2n (2N) selected.
13. Standard calibration for tension/compression load cells is in tension only.
14. Not available with amplified output.
15. Consult factory for TEDS availability with amplified models.
16. Range dependent; consult factory. Termination dependent; consult factory.
17. Internal amp and termination dependent; consult factory.
18. This unit calibrated to Imperial (non-Metric) units.

Warranty. Honeywell warrants goods of its manufacture as being free of defective materials and faulty workmanship. Honeywell's standard product warranty applies unless agreed to otherwise by Honeywell in writing; please refer to your order acknowledgement or consult your local sales office for specific warranty details. If warranted goods are returned to Honeywell during the period of coverage, Honeywell will repair or replace, at its option, without charge those items it finds defective. **The foregoing is buyer's sole remedy and is in lieu of all warranties, expressed or implied, including those of merchantability and fitness for a particular purpose. In no event shall Honeywell be liable for consequential, special, or indirect damages.**

While we provide application assistance personally, through our literature and the Honeywell web site, it is up to the customer to determine the suitability of the product in the application.

Specifications may change without notice. The information we supply is believed to be accurate and reliable as of this printing. However, we assume no responsibility for its use.

⚠ WARNING
PERSONAL INJURY

- DO NOT USE these products as safety or emergency stop devices or in any other application where failure of the product could result in personal injury.

Failure to comply with these instructions could result in death or serious injury.

⚠ WARNING
MISUSE OF DOCUMENTATION

- The information presented in this catalogue is for reference only. DO NOT USE this document as product installation information.
- Complete installation, operation and maintenance information is provided in the instructions supplied with each product.

Failure to comply with these instructions could result in death or serious injury.

Honeywell

Courtenay House, Monument Way East, Woking,
Surrey GU21 5LY, United Kingdom

Tel: +44(0)844 443 7925
Fax: +44(0)844 443 7928

Web Site: www.medcotas.com